



**ND 1000 E
Operating Instructions**

June 1997

Meret Optical Communications, Inc.



Index	Page
1 Introduction	I / 1
2 Installation	II / 1
2.1 Unpacking	II / 1
2.2 Setting up the ND 1000.....	II / 1
2.3 Mains Voltage	II / 2
2.4 Replacing a Fuse / Adjusting the Mains Voltage	II / 2
2.4.1 Replacing a Fuse	II / 3
2.4.2 Setting the Mains Voltage	II / 4
3 Construction of the ND 1000	III / 1
3.1 Front Panel	III / 1
3.2 Rear Panel	III / 2
4 Connections of the ND 1000	IV / 1
4.1 BNC-Connector of ND 1000.....	IV / 1
4.2 10 MHz Reference Input	IV / 1
4.3 10 MHz Reference Output	IV / 2
5 Operation of the Frequency Synthesizer ND 1000	V / 1
5.1 Power-on condition	V / 1
5.2 BCD-Remote	V / 1
5.3 RS 232 Interface	V / 1
5.4 Setting of the IEEE-listener address	V / 2
5.5 Setting frequency an power level	V / 3
5.5.1 Frequency Setting	V / 3
5.5.2 Power level setting	V / 3



6	Interfaces	VI / 1
6.1	BCD Interface.....	VI / 1
6.1.1	BCD modes.....	VI / 1
6.1.2	Pin Assignment of the BCD Interface mode 1: positive logic with store.....	VI / 2
6.1.3	Pin Assignment of the BCD Interface mode 2 and 3 Mode 2 positive logic transparentMode 3 negative logic transparent.....	VI / 3
6.1.4	Pin Assignment of the BCD Interface mode 4latch enable and remote enable.....	VI / 4
6.1.5	Pin Assignment of the BCD Interface mode 5double buffering, negative logic with store and remote enable.....	VI / 6
6.2	RS 232 Interface.....	VI / 8
6.2.1	Definition of the RS 232 interface.....	VI / 8
6.2.2	Pin Configuration of the RS 232 Interface.....	VI / 8
6.2.3	Connecting the ND 1000 to Personal Computer.....	VI / 9
6.2.4	Programming of the RS 232 Interface.....	VI / 9
6.2.4.1	Composition of a data block.....	VI / 9
6.2.4.2	Structure of RS 232 command PC → ND 1000.....	VI / 10
6.2.4.3	Structure of RS 232 message (echo) ND 1000 → PC.....	VI / 10
6.2.5	Instrument message for ND 1000.....	VI / 10
6.3	IEEE 488 Interface.....	VI / 11
6.3.1	Description of the IEEE 488 Interface.....	VI / 13
6.3.1.1	Data Bus.....	VI / 13
6.3.1.2	Control Bus.....	VI / 13
6.3.1.3	Handshake Bus.....	VI / 14
6.3.2	Structure of the IEEE 488 interface.....	VI / 14
6.3.3	Setting of the IEEE Listener address at the ND 1000.....	VI / 15
6.3.4	Interface Messages.....	VI / 16
6.3.4.1	Universal Instructions.....	VI / 16
6.3.4.2	Addressed Instructions.....	VI / 16
6.3.5	Instrument Messages.....	VI / 18
6.3.5.1	Structure of an instrument message.....	VI / 18
6.3.5.2	Instrument messages for the ND 1000.....	VI / 18
7	Appendix	VII / 1
7.1	Technical Specifications ND 1000.....	VII / 1
7.2	Service: Reference frequency calibration.....	VII / 2
7.3	Ordering Specifications ND 1000 Series.....	VII / 2



1 Introduction

The frequency synthesizer ND 1000 is a direct synthesizer RF-generator. The output frequency is set in exactly decade-related steps with 0.1Hz resolution (0.2 Hz \geq 500 MHz). The accuracy of the output frequency is solely determined by the frequency reference.

Combining conventional RF-modules for greater frequency steps with a DDS (**D**irect **D**igital **S**ynthesizer) for smaller frequency steps makes possible excellent technical data for residual FM, high spectral purity and very fast frequency-switching, realized in a small packing.

Besides internal synchronization by the standard OCXO, frequency synthesizers of the ND 1000 series can be synchronized externally in order to access the same reference when operated along with other instruments or to benefit from the stability of an external standard. On the other hand, the frequency synthesizer's high precision OCXO can also synchronize other instruments.

The two differently equipped instrument types ND 1000 S and ND 1000 D are based upon the same technology as the base version ND 1000, used along with various interfaces (BCD, RS 232, IEEE-BUS) they provide optimum match to the specific measuring problem.

Applications of the frequency synthesizers include:

- use in nuclear magnetic resonance spectroscopy, electron spin resonance spectroscopy and microwave spectroscopy.
- transmitting- and receiving section of terrestrial and satellite radio systems.
- fast automatic test systems for antenna-, instrument- and component testing.
- settable frequency reference, derived from frequency standards or used as high precision local oscillator for research and development, etc.

Besides, frequency synthesizers can replace complicated PLL-synthesizers, for which modulation of the carrier is not the key problem, but accuracy, frequency stability and spectral purity are essential.

The Schomandl frequency standard FN-77 and the FN-GPS are particularly suitable for external 10 MHz frequency standards; the FN-77 is based upon the frequency of the long wave transmitter DCF 77 for use in Central Europe whereas the FN-GPS using signals from the GPS-satellite system can be used anywhere in the world.



2 Installation

2.1 Unpacking

Please check the instrument immediately after unpacking for possible transportation damage. When a damage has occurred, please keep packing material, invoice and transportation documents completely since all these items are required to treat that damage. Please inform your nearest dealer immediately. Check the completeness of the delivery by means of the delivery note. In case of any discrepancy, please inform your nearest dealer.



Note:

- for shipping or storing your instrument, please use the original package, if possible. If that is not available, you are advised to use an equivalent package, offering best possible protection for your instrument.
- please always enclose a dehydrating agent to the package in order to protect your instrument from penetrating humidity.
- please observe the storing temperatures as given in the technical specifications.

2.2 Setting up the ND 1000

- make sure your instrument gets sufficient ventilation.
- if several instruments are to be operated one atop of another, the frequency synthesizer should be on top.
- in order to avoid heat accumulation, no object should block the ventilator opening and the ventilation holes on the upper and lower surface.



Attention:

Never deposit anything on the instrument.

- in order to avoid damage to the frequency synthesizer and to the instruments connected thereto, all plug-ins and unplugs have to be carried out with AC-power off.



2.3 Mains Voltage

Before switching on the instrument, please check whether the operating voltage the instrument is set to complies with the local mains voltage.

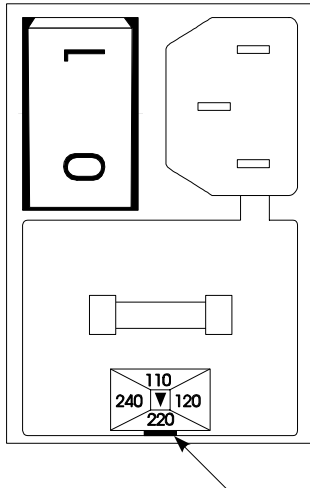

The operating voltage set for the instrument is indicated below the power connection.

An arrow indicates the set voltage.



Attention:

Wrongly set operating voltage may destroy the instrument. Schomandl is not liable for any damage resulting from wrongly set voltage.

2.4 Replacing a Fuse / Adjusting the Mains Voltage

If the local mains voltage does not correspond to the mains voltage the instrument is set to, or if the mains fuse has to be replaced, proceed as follows:

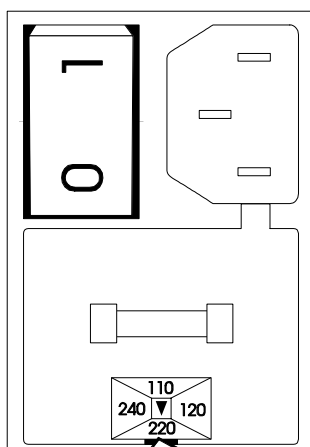

Remove the fuse block from its support by inserting a screwdriver into the prepared recess below the fuse block, use it as a lever and remove the fuse block from its support.



2.4.1 Replacing a Fuse

- Press the bolt of the 'fuse compartment' slightly upwards ① and then pull out the fuse carrier ②.

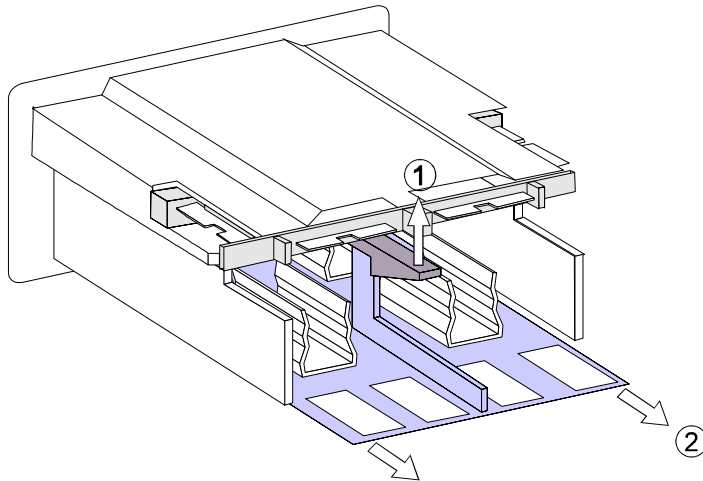
**Note:**

Only use the following fuse-types:

For 220...240V AC	Slow-Blow 2,0A
For 110...120V AC	Slow-Blow 5,0A

- After replacing the fuse push back the fuse carrier into its support.



2.4.2 Setting the Mains Voltage

- press the bolt of the 'coding plug' slightly upwards ①, then pull out the coding-plug ②.
- Re-insert the coding plug in such a way, that desired voltage is shown in the front panel window of the fuse carrier.
- Make sure, desired voltage is shown in the fuse-carrier window. (see also 2.3)

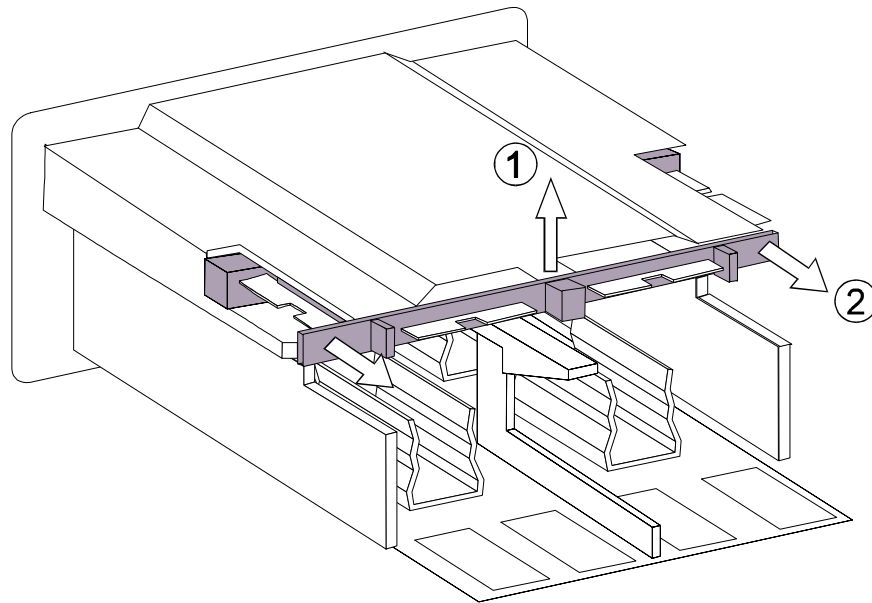

Note:

- Frequency Synthesizers of ND 1000 series are labelled 'CE'.
- Electric fields having field strengths of maximum 10V/m do not degrade performance of the instrument in any way.
- With respect to electrical safety precautions, these frequency synthesizers are tested according to standard VDE 0411, safety class 1.
- Frequency synthesizers of the ND 1000 series are manufactured according to standard ISO 9001.



3 Construction of the ND 1000

3.1 Front Panel

All control knobs are located on the front panel.

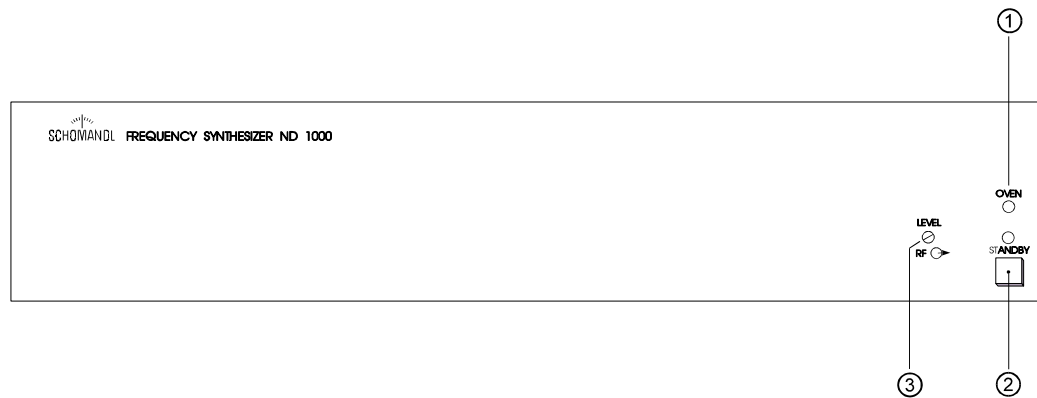

Standby

- Pushbutton for temporary desactivation of signal generator
LED lights yellow for STANDBY and green for regular operation mode
- on STANDBY mode only OCXO is running

OVEN (LED operation status indicator of the quartz oven heating)

- orange: operating temperature not yet reached.
- green: operating temperature reached.

Level

- < 0 ... + 15 dBm setting range (done via slot-screw)



3.2 Rear Panel

On the rear panel of the ND 1000 the interfaces, frequency reference in- and outputs and the AC power connector are located.

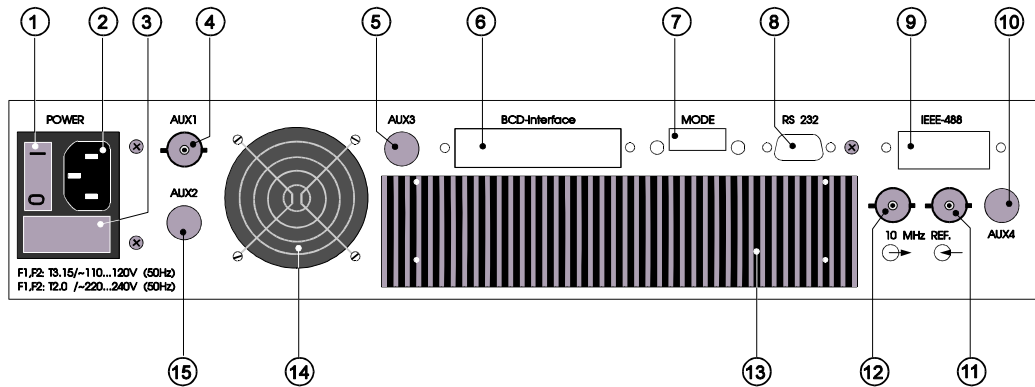

Mains switch (Power ON)

AC power connector

Mains fuses

- ④ **AUX 1- RF Output**
 - BNC-socket
- ⑤ **AUX 3** not being used
- ⑥ **BCD-parallel-interface**
 - optional parallel interface
- ⑦ **Mode**
 - DIP switch for configuration of BCD parallel-interface and IEEE-Listener-address
- ⑧ **RS 232 interface**
 - optional serial interface
- ⑨ **IEEE-488 bus**
 - optional IEEE 488 interface
- ⑩ **AUX 4** not being used
- ⑪ **10 MHz reference input**
- ⑫ **10 MHz reference output**
- ⑬ **Heat sink**
- ⑭ **Ventilator**
- ⑮ **AUX 2** not being used



4 Connections of the ND 1000

Attention:

Plugging or unplugging may only be done when instrument is switched off. Possibly occurring peak current may destroy unit.

4.1 BNC-Connector of ND 1000

Signal output of the ND 1000 is via BNC-connector located on the rear panel bearing the label AUX 1.

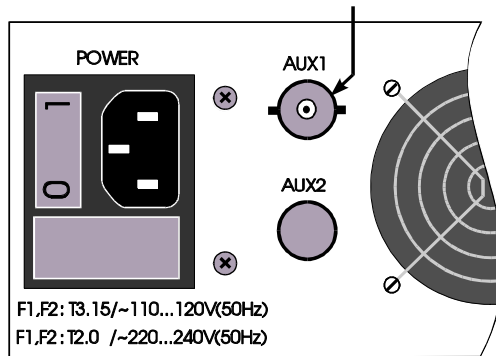

4.2 10 MHz Reference Input

External frequency reference for the ND 1000 is fed in here.



External
fulfil
2 MHz,
0dBm ... + 8 dBm

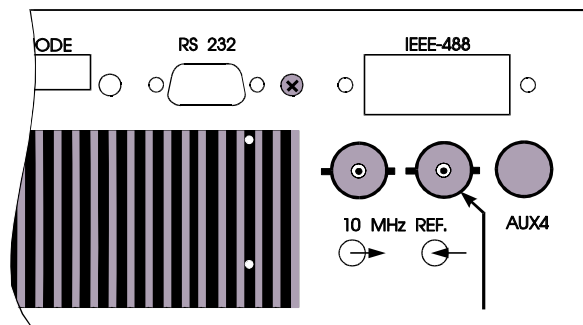

Note:

frequency reference must
specifications as follows:
5 MHz, 10 MHz \pm 2 Hz;



4.3 10 MHz Reference Output

This output can be used as frequency reference for other instruments.

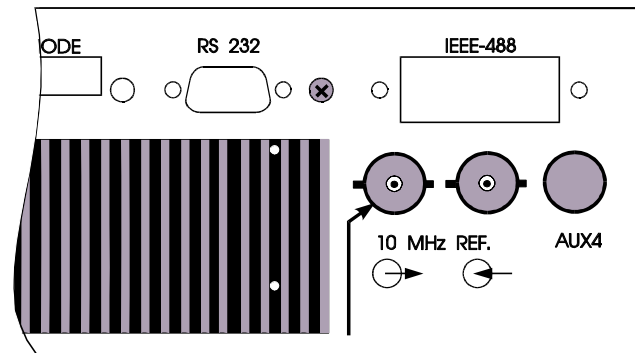

Output level: + 10 dBm

The reference output of the ND 1000 has following specifications:

Frequency:	10 MHz
Temperature coefficient:	$< 3 \cdot 10^{-9}/K$
Aging:	$< 2 \cdot 10^{-8}/mo$



Attention:

Pulling of the ND 1000's internal reference must be avoided, using external attenuators or buffers for example.



5 Operation of the Frequency Synthesizer ND 1000

5.1 Power-on condition

Generally, the BCD interface is active every power switch on of the frequency synthesizer ND 1000.

Transition from BCD interface to RS 232- or IEEE-interface is automatically done by a valid RS 232- or IEEE-instruction. (see also chapter 6.2 and 6.3)

In order to re-activate the BCD interface, power of the frequency synthesizer has to be turned off and on again.



Note:

Simultaneous operation of IEEE- and RS 232-interface is not allowed!

5.2 BCD-Remote

The ND 1000 has a parallel BCD-interface and hereby features extremely fast access to the instrument. The DIP-mode-switches configure the 50-pin interface (also see chapter 6.1).

5.3 RS 232 Interface

The optionally available RS 232-interface is a 9-pin standard connector. (also see chapter 6.2).



5.4 Setting of the IEEE-listener address

Setting of the IEEE-listener address is done on 'power off' by Mode-DIP-switch.

Proceed as

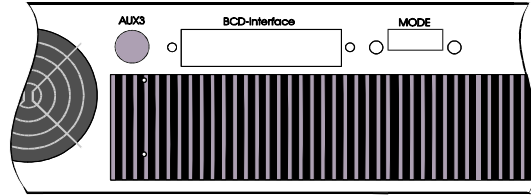

follows:

- by DIP-switch 6.
- DIP-switches 1 - 5 define digitally the value. LSB = DIP 1 for listener address. (The system accepts addresses between 00 and 30)
- Switch on the ND 1000.
- In order to store the IEEE-listener-address turn off the ND 1000 and activate BCD-mode by turning DIP-switch 6 off.
- Be sure, current BCD-mode-setting is valid! (also see chapter 6.1.1)
- After turning power on again, the new IEEE-listener-address is initialized.

Activate the IEEE-ADR-mode in **ON** position

Examples:

IEEE-Listener address	DIP-switches					LSB
	6	5	4	3	2	1
address 1	ON	OFF	OFF	OFF	OFF	ON
address 4	ON	OFF	OFF	ON	OFF	OFF
address 8	ON	OFF	ON	OFF	OFF	OFF

Note:

Manufacturer's setting of IEEE-listener address is 10. (also refer to chapter 6.3)



5.5 Setting frequency and power level

The ND 1000 generates frequencies between 10 000 Hz and 999 999 999,9 Hz in 0,1 Hz (0,2 Hz \geq 500 MHz) increments. Power level is settable between < 0 and $+ 15$ dBm. Below specified frequency of 100 kHz, frequencies down to 0 Hz can be entered. However, be aware of the fact that power levels are not defined then.

5.5.1 Frequency Setting

Frequency setting of the ND 1000 is generally done via remote control. Several different interfaces are available:

- BCD-parallel interface
- RS 232 (optionally available)
- IEEE 488-Bus (optionally available)

5.5.2 Power level setting

Power level can be set by rotating the slot-screw on front panel.

- Rotate counterclockwise to decrease power level (min. < 0 dBm)
- Rotate clockwise to increase power level (max. $+ 15$ dBm)



Note:

- Default setting is $+ 13$ dBm ± 1 dBm.
- Power output is specified only for frequency range 10 000 Hz to 999 999 999,8 Hz.



6 Interfaces

6.1 BCD Interface

The optionally available parallel BCD interface allows extremely fast setting or frequency control by a remote control. The 50-pin BCD interface is being configured by the mode DIP switch.

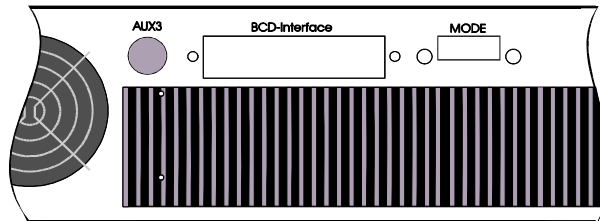

6.1.1 BCD modes

BCD modes are activated by OFF-position of SIP-switch 6. These configurations of the BCD-interface are possible:

Mode	Configuration	DIP - Switch					
		6	5	4	3	2	1
1	BCD-parallel mode (positive logic with store)	-	ON	-	ON	ON	ON
2	BCD-parallel mode (positive logic transparent)	-	ON	-	ON	ON	OFF
3	BCD-parallel Modus (negative logik transparent)	-	OFF	-	ON	OFF	ON
4	BCD-parallel Modus (negative logik transparent mit 'Latch Enable' und 'Remote Enable')	-	OFF	-	ON	OFF	OFF
5	BCD-parallel Modus (double buffering, negative logic with store and 'Remote-Enable')	-	OFF	-	OFF	ON	OFF

Note:

- The DIP-switch 5 activates 10kΩ-Resistors to pull-down (to GND) or to pull up (against +5V) the plug inputs pin 1...21 and pin 23...49 for Dip-switch 5 setting ON or OFF respectively.
- Dip-switch 6 must be set OFF to operate the BCD-interface.

Attention:

New interface configurations are initialized only after switching the instrument off and then on again.



6.1.2 Pin Assignment of the BCD Interface mode 1: positive logic with store

PIN	Function	PIN	Function
1	100 kHz	26	400 kHz
2	200 kHz	27	800 kHz
3	10 kHz	28	40 kHz
4	20 kHz	29	80 kHz
5	1 kHz	30	4 kHz
6	2 kHz	31	8 kHz
7	100 Hz	32	400 Hz
8	200 Hz	33	800 Hz
9	10 Hz	34	40 Hz
10	20 Hz	35	80 Hz
11	1 Hz	36	4 Hz
12	2 Hz	37	8 Hz
13	0,1 Hz	38	0,4 Hz
14	0,2 Hz	39	0,8 Hz
15	10 MHz	40	40 MHz
16	20 MHz	41	80 MHz
17	1 MHz	42	D (frequency doubler)
18	2 MHz	43	100 MHz
19	4 MHz	44	200 MHz
20	8 MHz	45	nc
21	nc	46	nc
22	nc	47	nc
23	nc	48	take over (pos. slope)
24	nc	49	400 MHz
25	nc	50	GND

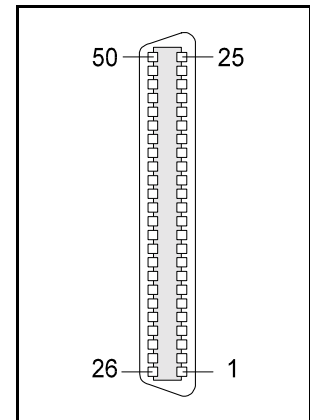

Note:

Storing takes place at positive slope of UALL signal. Rise time must be less than 500ns at TTL-level.



6.1.3 Pin Assignment of the BCD Interface mode 2 and 3
Mode 2 positive logic transparent
Mode 3 negative logic transparent

PIN	Function	PIN	Function
1	100 kHz	26	400 kHz
2	200 kHz	27	800 kHz
3	10 kHz	28	40 kHz
4	20 kHz	29	80 kHz
5	1 kHz	30	4 kHz
6	2 kHz	31	8 kHz
7	100 Hz	32	400 Hz
8	200 Hz	33	800 Hz
9	10 Hz	34	40 Hz
10	20 Hz	35	80 Hz
11	1 Hz	36	4 Hz
12	2 Hz	37	8 Hz
13	0,1 Hz	38	0,4 Hz
14	0,2 Hz	39	0,8 Hz
15	10 MHz	40	40 MHz
16	20 MHz	41	80 MHz
17	1 MHz	42	D (frequency doubler)
18	2 MHz	43	100 MHz
19	4 MHz	44	200 MHz
20	8 MHz	45	nc
21	nc	46	nc
22	nc	47	nc
23	nc	48	nc
24	nc	49	400 MHz
25	nc	50	GND

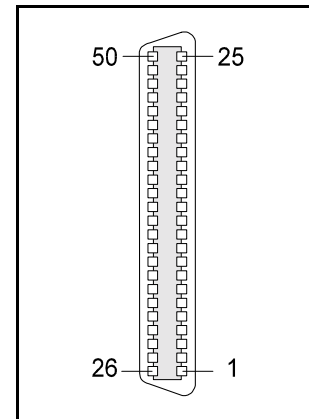

6.1.4 Pin Assignment of the BCD Interface mode 4 latch enable and remote enable

PIN	Function	PIN	Function
1	100 kHz	26	400 kHz
2	200 kHz	27	800 kHz
3	10 kHz	28	40 kHz
4	20 kHz	29	80 kHz
5	1 kHz	30	4 kHz
6	2 kHz	31	8 kHz
7	100 Hz	32	400 Hz
8	200 Hz	33	800 Hz
9	10 Hz	34	40 Hz
10	20 Hz	35	80 Hz
11	1 Hz	36	4 Hz
12	2 Hz	37	8 Hz
13	0,1 Hz	38	0,4 Hz
14	0,2 Hz	39	0,8 Hz
15	10 MHz	40	40 MHz
16	20 MHz	41	80 MHz
17	1 MHz	42	REM
18	2 MHz	43	100 MHz
19	4 MHz	44	200 MHz
20	8 MHz	45	800 MHz
21	nc	46	LE 10 Hz - 800 Hz
22	nc	47	LE 0,1 Hz - 8 Hz
23	LE 10 MHz - 800 MHz	48	nc
24	LE 100 kHz - 8 MHz	49	400 MHz
25	LE 1 kHz - 80 kHz	50	GND

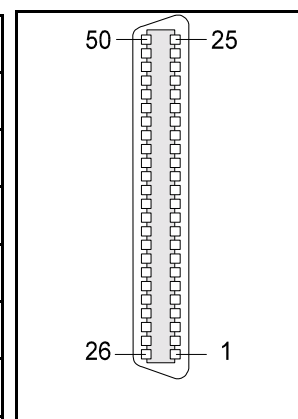

**Note:**

- **GND:** Ground
- **LE:** **High:** The data enters the latches, the latches are transparent.
Low: The latches store the information that was present on the data inputs during the HIGH-to-LOW transition of LE.
- **REM:** **High:** Remote Control is disabled. The data enters the input-latches, but the output frequency is set to 0 Hz (no output signal).
Low: Remote Control is enabled.

**Attention:**

PIN 45 has to be set to HIGH-level using either the DIP-switch (DIP 5 =OFF) or an external voltage (+5V).



6.1.5 Pin Assignment of the BCD Interface mode 5 double buffering, negative logic with store and remote enable

PIN	Function	PIN	Function
1	100 kHz	26	400 kHz
2	200 kHz	27	800 kHz
3	10 kHz	28	40 kHz
4	20 kHz	29	80 kHz
5	1 kHz	30	4 kHz
6	2 kHz	31	8 kHz
7	100 Hz	32	400 Hz
8	200 Hz	33	800 Hz
9	10 Hz	34	40 Hz
10	20 Hz	35	80 Hz
11	1 Hz	36	4 Hz
12	2 Hz	37	8 Hz
13	0,1 Hz	38	0,4 Hz
14	0,2 Hz	39	0,8 Hz
15	10 MHz	40	40 MHz
16	20 MHz	41	80 MHz
17	1 MHz	42	REM
18	2 MHz	43	STROBE
19	4 MHz	44	800 MHz
20	8 MHz	45	400 MHz
21	nc	46	RSTR 10 Hz - 800 Hz
22	nc	47	RSTR 0,1 Hz - 8 Hz
23	RSTR 10 MHz - 800 MHz	48	200 MHz
24	RSTR 100 kHz - 8 MHz	49	100 MHz
25	RSTR 1 kHz - 80 kHz	50	GND

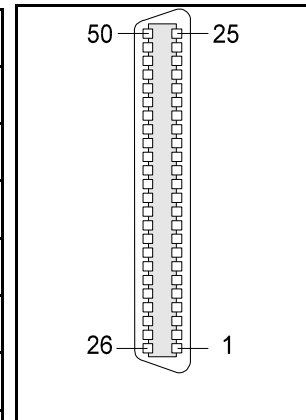

**Note:**

- **GND:** Ground
- **RSTR:** A LOW-to-HIGH transition of the register strobe input will store the data into the first rank of buffers.
- **REM: High:** Remote Control is disabled.
The data enters the input-latches, but the output frequency is set to 0 Hz (no output signal).
Low: Remote Control is enabled.
- **STROBE:** A LOW-to-HIGH transition of the strobe no sooner than 100ns after the LOW-to-HIGH transition of the RSTR lines will clock the data into the second rank of buffers to start the change of frequency.

**Attention:**

Changes of state of REM pin and of STROBE pin must differ 200ns minimum.

PIN 44 has to be set to HIHG-level using either the DIP-switch (DIP 5 =OFF) or an external voltage (+5V).



6.2 RS 232 Interface

The optionally available serial RS 232 interface is a standard 9-pin connector. This interface is used to control the frequency synthesizer via PC software.

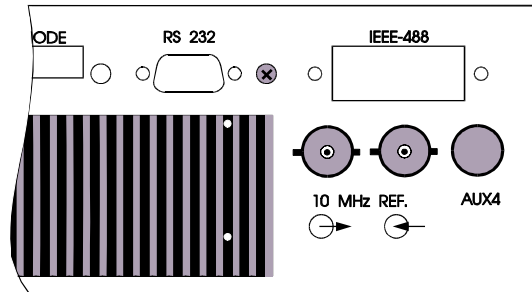

6.2.1 Definition of the RS 232 interface

- DCD = data transmission identified
- RX = data receiver
- TX = data transmitter
- DTR = data terminal ready
- DSR = Data set ready
- RTS = Ready to send
- CTS = standby for data transmission
- RI = identification

6.2.2 Pin Configuration of the RS 232 Interface

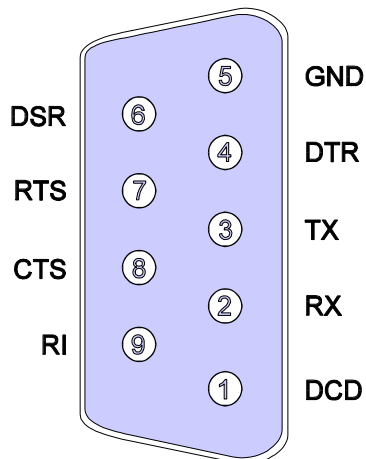

6.2.3 Connecting the ND 1000 to Personal Computer

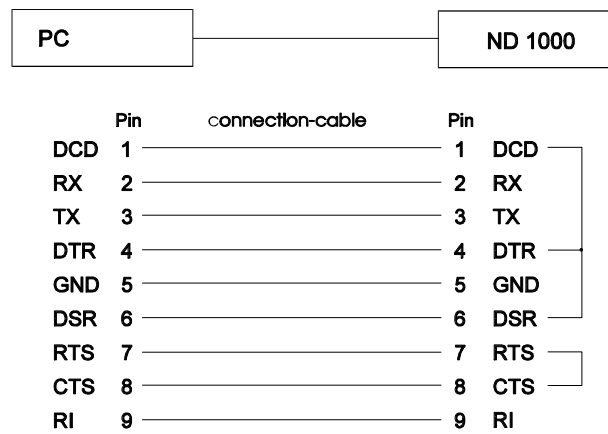

6.2.4 Programming of the RS 232 Interface



Attention:

Simultaneous operation of IEEE- and RS 232-interface is not allowed!

6.2.4.1 Composition of a data block

The RS 232 interface is operated in following mode:

Baudrate:	4.8 k Baud
start bit	1 bit
data bits	8 bits
stop bit	1 bit
parity bit	no bit

Every valid RS 232 instruction from the PC is followed by an echo from the ND 1000 containing the new setting.

In case of invalid RS 232 instruction, no new setting is transmitted; the message '\$ERROR CR+LF' is transmitted to PC.



6.2.4.2 Structure of RS 232 command PC → ND 1000

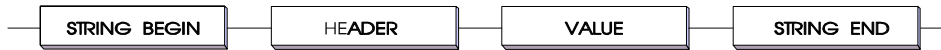

6.2.4.3 Structure of RS 232 message (echo) ND 1000 → PC

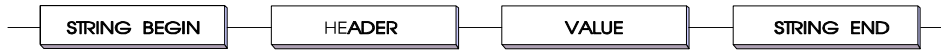

- **String Begin:** consists of the \$-sign
- **Header:** The header is the actual instruction and always consists of 4 characters.
- **Value:** value assigned to instruction. The number of characters depends on the instruction.
- **String End:** has to follow the last character of the value and consists of CR and LF (13+10)

6.2.5 Instrument message for ND 1000

Following instructions are required to control the frequency synthesizer ND 1000:

Start	Header	Value	End	Unit	Description
\$	frq_	xxx.xxxxxx	CR+LF	[MHz]	set RF-frequency
\$	gtbcd		CR+LF		get back to BCD-Remote



Note:

- The Header always consists of 4 characters, meaning that frq always must be programmed followed by a (_).
- Setting range for RF-frequencies: 0.0000001...999.9999998 MHz
- Setting of appropriate units is not required, since always MHz are being used.



Example:

Programming 10.1234567 MHz: \$frq_10.1234567CRLF
 Programming 100.1234567 MHz: \$frq_100.1234567CRLF



6.3 IEEE 488 Interface

The optional IEEE 488 interface complies with standard IEC 625 and IEEE 488. It enables various measurement instruments and computers to exchange data via the data bus. All connected instruments are parallel to this bus and access all data lines.

The instruments connected to the IEEE bus can, according to their function, send or receive messages (Talker and Listener respectively).

The instruments connected to an IEEE bus system are distinguished as follows:

- **Listener:** can only receive data
- **Talker:** can only transmit data
- **Talker/Listener:** can as well receive and transmit data
- **Controller:** controls the functions and exchange of information between the instruments. (i.e. computers)

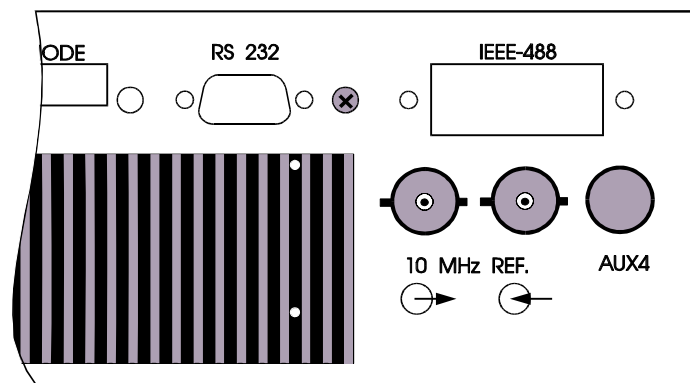

Note:

The ND 1000 are operated in Listener mode.

Data transfer between the individual connected instruments is done serial by byte. In order to make instruments with different execution speed operate on the bus, data exchange is done in connection with a three-step handshake process.

The bus employs negative logic and can be operated with a maximum cable length of 20 meters.



Attention:

Simultaneous operation of IEEE- and RS 232-interface is not allowed!

6.3.1 Description of the IEEE 488 Interface



The IEEE 488 connection socket is located at the rear panel of the frequency synthesizer. The interface contains 16 bus lines which can be combined in 3 groups (data bus, control bus, handshake bus).

6.3.1.1 Data

The data bus

- DIO 1... DIO
- LSB = DIO

6.3.1.2 Control

The control bus

- ATN

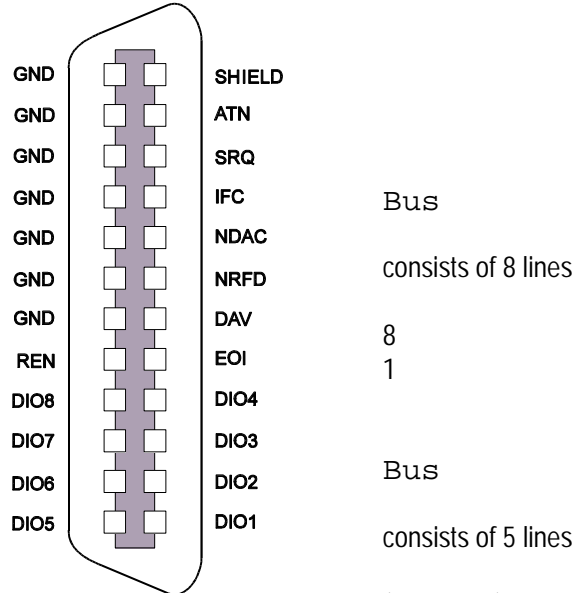

(Attention): ATN is activated when addresses, universal and addressed instructions are being sent.

- **REN (Remote Enable):** Switches on or off the remote control of the instrument.
- **SRQ (Service Request):** The instrument sends an operation call to the controller.
- **IFC (Interface Clear):** This signal is activated by the controller to preset the instruments connected to IEEE bus to a defined state. ATN signal the controller calls for parallel scan.
- **EOI (End or Identify):** The last byte of a data transfer is transmitted. In conjunction with ATN, the controller requests for a parallel search.



6.3.1.3 Handshake Bus

The handshake bus consists of 3 lines:

- **DAV (Data valid):** The DAV signal is activated whenever new valid data are available on the bus.
- **NRFD (Not ready for Data):** signalizes to the talker, that data cannot yet be accepted (active at logic LOW)
- **NDAC (Not Data Accepted):** One of the listeners has not yet accepted offered data.

6.3.2 Structure of the IEEE 488 interface

The IEEE 488 interface is according to IEEE standard 488-1978 and contains the following equipment:

SH1:	Talker's Handshake	NO
AH1:	Listener's Handshake	YES
L4:	no listen only	YES
	unlisten by addressing as talker	YES
T8:	Serial Poll	NO
	Talker only	NO
SRO:	Service Request	NO
PPO:	Parallel Poll	NO
RL2:	Local lock out	NO
DC1:	Device clear	YES
	Select driver clear	YES
DTO:	Device Trigger	NO



6.3.3 Setting of the IEEE Listener address at the ND 1000

Setting of the IEEE-listener address is done on 'power off' by Mode-SIP-switch.

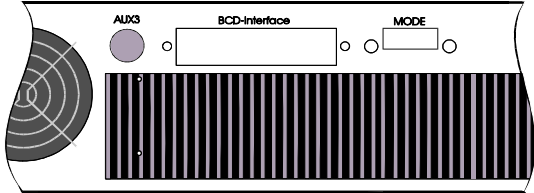
Proceed  as follows:

Activate the IEEE-ADR-mode in **ON** position

- by DIP-switch 6.
- DIP-switches 1 - 5 define digitally the value. LSB = DIP 1 for listener address. (The system accepts addresses between 00 and 30)
- Switch on the ND 1000.
- In order to store the IEEE-listener-address turn off the ND 1000 and activate BCD-mode by turning DIP-switch 6 off.
- Be sure, current BCD-mode-setting is valid! (also see chapter 6.1.1)
- After turning power on again, the new IEEE-listener-address is initialized.

 **Examples:**

IEEE-Listener address	DIP-switches					LSB
	6	5	4	3	2	1
address 1	ON	OFF	OFF	OFF	OFF	ON
address 4	ON	OFF	OFF	ON	OFF	OFF
address 8	ON	OFF	ON	OFF	OFF	OFF

 **Note:**

Manufacturer's setting of IEEE-listener address is 10. (also refer to chapter 6.3)



6.3.4 Interface Messages

Interface messages are transferred to the data lines of the ND 1000 when ATN (Attention) is active. They are used to control the instruments connected to the IEEE bus; that means, these instruments are set to an instrument-specific state. These data can be classified in two different groups:

- universal instructions
- addressed instructions

6.3.4.1 Universal Instructions

Universal instructions are valid for all connected IEEE bus users. For the ND 1000 only the instruction DCL is relevant.

- **DCL (Device Clear)** Resets the ND 1000 into its original state. Thus, it has the same effect as switching on the instrument again.

6.3.4.2 Addressed Instructions

Addressed instructions are effective only on IEEE-bus users which are addressed as listeners. For the ND 1000 only two instructions are relevant.

- **SDC (Select Device Clear)** Resets the ND 1000 in its original state. Thus, it has the same effect as switching on the instrument again.
- **GTL (Go to Local)** Switches the ND 1000 to manual operation.

Please refer to following IEC-character-set table to see the IEEE instructions:

controlcode					digits and special characters				capital letters				small letters				
0	NUL		16	DLE		32	SP	48	0	64	@	80	P	96	'	112	p
1	SOH	GTL	17	CD1		33	!	49	1	65	A	81	Q	97	a	113	q
2	STX		18	DC2		34	"	50	2	66	B	82	R	98	b	114	r
3	ETX		19	DC3		35	#	51	3	67	C	83	S	99	c	115	s
4	EOT	SDC	20	DC4	DLC	36	\$	52	4	68	D	84	T	100	d	116	t
5	ENQ	PPC	21	NAK	PPU	37	%	53	5	69	E	85	U	101	e	117	u
6	ACK		22	SYN		38	&	54	6	70	F	86	V	102	f	118	v
7	BEL		23	ETB		39	'	55	7	71	G	87	W	103	g	119	w
8	BS	GET	24	CAN	SPE	40	(56	8	72	H	88	X	104	h	120	x
9	HT	TCT	25	EM	SPD	41)	57	9	73	I	89	Y	105	i	121	y
10	LF		26	SUB		42	*	58	:	74	J	90	Z	106	j	122	z
11	VT		27	ESC		43	+	59	;	75	K	91	[107	k	123	{
12	FF		28	FS		44	,	60	<	76	L	92	\	108	l	124	
13	CR		29	GS		45	-	61	=	77	M	93]	109	m	125	}
14	SO		30	RS		46	.	62	>	78	N	94	^	110	n	126	~
15	SI		31	US		47	/	63	UNL	79	O	95	_	111	o	127	DEL
addressed instructions		universal instructions			listener address				memory address				sekundary addresses and -instructions				

6.3.5 Instrument Messages



In contrast to the interface messages, instrument messages are actually those instructions transferring data to the IEEE bus users. Instrument messages are transferred to the data lines of the ND 1000 when ATN (Attention) is **not active**. For these messages, the ISO-7-Bit ASCII Code is used.

6.3.5.1 Structure of an instrument message

The messages which can be received in listener-mode are composed of the following items:



- **Header:** The header corresponds to the instruction and always consists of 4 characters.
- **Value:** the value corresponding to the header used. Number of characters depends on the instruction.
- **EOI (End or Identify):** The last byte of a data transfer is transmitted.

6.3.5.2 Instrument messages for the ND 1000

Operation of the ND 1000 requires one instruction.

Header	Value	Unit	Description
frq_	xxx.xxxxxxx	[MHz]	set RF-frequency
gtbcd			get back to BCD-Remote

 **Note:**

- The header always consists of 4 characters; frq_ always have to be programmed with a following (_).
- Setting range for frequencies: 0.0000001...999.9999998 MHz
- Entering units is not required, since always MHz are used.

 **Examples:**

Programming 10.1234567 MHz: frq_10.1234567
 Programming 100.1234567 MHz: frq_100.1234567



General Features

Power supply: 110/120/220/240V ± 10%
 Power consumption, frequency: 47...63 Hz, 88 VA, 9VA stand-by
 Electric security:..... VDE 0411, Protective Class 1
 Interference suppression: CE-mark
 Maximum field strength:..... > 10V/m
 Manufacturing standard: according to ISO 9001
 Operating temperature: +5°C...+45°C
 Storage temperature:..... -10°C...+60°C
 Dimensions 19"-adapter (W x H x D): 19" x 2 HE x 450 mm
 Weight: approx. 13 kg

Accessories supplied:

1 piece power cord
 1 piece operating manual German/English
 1 set..... spare fuses

7.2 Service: Reference frequency calibration

With respect to the xtal's aging, an annual control/correction is recommend. An adequate reference source, e.g. Schomandl FN77 or FN-GPS, and an oszilloscope to represent the Lissajous's figure, are required for comparison.

In order to do this, check for a plug on bottom-side, nearby the reference-output.



Attention:

Open the plug and
 screwdriver (plastic)

This calibration
 technician.

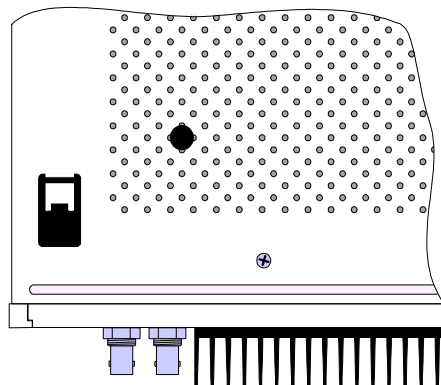

calibrate with an ironless
 e.g. Bernstein 1-306.

requires an authorized

7.3 Ordering

Specifications
 Series

ND 1000

Frequency Synthesizer ND 1000 BN 86305.000
 Option IEEE-Bus and RS 232 BN 86301.101

